

Hartzell

AIR MOVEMENT

DM018

1/23/2025

For units with order numbers after 2520000

ORDER#

MODEL#

BTU RATING / BURNER PRESSURE

TABLE OF MAJOR COMPONENTS

Wiring Dia. Symbol	Manufacturer	Hartzell Part No.	Publication	Description
CRE	Fireye	5919-018	MC-5000	M-Series Chassis
		5919-017	MP-5101	Programing Card
		5919-016	MAMP-1	Flame Sensor Amplifier Card
LS	Eaton	6117-015	P50214 Rev 03	DOOR SWITCH
FLS	Antunes	6113-019	SMD 1011083	DIFFERENTIAL PRESSURE SWITCH
M	Eaton	6101-389		MOTOR STARTER WITH OVERLOADS
1V	DUNGS	6121-011	DMV-D(LE) 7../622	1ST SAFETY SHUTOFF VALVE (W/POC)
3V	DUNGS		DMV-D(LE) 7../622	2ND SAFETY SHUTOFF VALVE
1PS	DUNGS		Gxx-A2	HIGH GAS PRESSURE SWITCH
2PS	DUNGS		Gxx-A2	LOW GAS PRESSUER SWTICH
POC, 1v	DUNGS			PROOF OF COLSURE SWITCH
2THS	THERM-O-DISC		6114-043	60T Series
2V	Honeywell	6109-071	V4046C	PILOT GAS SOLENOID VALVE
SC	Fireye	5919-020		UV FLAME SCANNER
2T	HONEYWELL	6112-021		IGNITION TRANSFORMER
ST	CROWN ENGINEERING	6124-097		SPARK IGNITOR (CP-19)
1CR AND 2CR	EATON	6119-028		CONTROL RELAYS, 120V
1TDR	IDEC	6119-010		TIME DELAY RELAY (ON-DELAY TYPE)



Phone: 1-800-336-3267

Website: www.hartzellairmovement.com

Email: info@hartzell.com



The first and only 5-year warranty in the industry

We're so confident in our design, materials and workmanship that every product we sell is eligible for our full 5-year warranty. We're the first – and still the only – industrial air movement manufacturer who offers that kind of performance guarantee.

Performance Guarantee

You have high expectations. So does Hartzell Air Movement. We know you demand the most reliable and durable industrial air movement products available, so we're holding ourselves to a higher standard. We're so sure that our products will out-perform industrial standards, we're backing that promise with the industry's first five-year warranty.

The 5-year warranty is free but your product must be registered to be eligible!



Register for your 5-year warranty at:

<https://www.hartzellairmovement.com/resources/warranty-and-parts/>

New users will need to click CREATE AN ACCOUNT.

Returning users will need to LOG IN.

You will need the serial number and purchase date of each product you would like to register. Contact your Hartzell Air Movement Representative for assistance.

See Warranty Terms and Conditions for more information.

TERMS AND CONDITIONS OF SALE OF HARTZELL FAN, INC. dba "HARTZELL AIR MOVEMENT"

These Terms and Conditions of Sale should be read carefully. Sale of any goods or services described or referred to herein is subject to these Terms and Conditions of Sale. Any order for or any statement of intent to purchase any goods or services, or any direction to proceed with engineering, procurement, manufacture or shipment, constitutes assent to these Terms and Conditions of Sale.

REJECTION OF DIFFERENT TERMS - This document is not an acceptance of any prior written or oral offer. If any such prior written or oral offer has been made, it is hereby rejected. These Terms and Conditions of Sale supersede any additional or different written or oral terms previously or subsequently communicated. Acceptance is expressly limited to these Terms and Conditions of Sale. Hartzell Air Movement hereby gives notification of its objection to and rejection of any proposed terms different from those contained herein whether communicated previously or subsequently and whether written or oral. This document is the complete and exclusive statement of the agreement between Hartzell Air Movement and Buyer.

DELIVERY - Shipping dates are approximate and are based upon prompt receipt of all necessary information. Hartzell Air Movement is not liable for delays in delivery or in performance or failure to manufacture or deliver, due to (1) causes beyond its reasonable control, including errors in manufacture or (2) acts of God, acts of the Buyer, acts of civil or military authority, priorities, fires, strikes, or other labor disturbances, floods, epidemics, war, riot, delays in transportation or car shortage, or (3) inability on account of causes beyond its reasonable control to obtain necessary labor, materials, components or manufacturing facilities. In the event of any such delay, the date of delivery or of performances shall be extended for a period equal to the time lost by reason of delay.

START-UP SERVICE - On certain equipment start-up service is available from Hartzell Air Movement at per diem rates plus lodging and traveling expenses. Such start-up service is not included unless specifically quoted. There will be an additional charge for time used exceeding any number of days quoted.

ELECTRICAL EQUIPMENT - Equipment includes only the electrical components referred to in the proposal. Charges arising from any local, state, provincial or other regulations necessitating changes to electrical equipment will be paid by Buyer unless agreed otherwise in writing by Hartzell Air Movement.

CANCELLATION/TERMINATION/MODIFICATION - There can be no cancellation, termination or modification by Buyer without Hartzell Air Movement's prior written consent.

CLAIMS - Claims of shortages or errors or other basis for rejection must be made within five (5) days after delivery.

PRICING - Prices quoted are firm provided release to manufacture and shipment is completed by Hartzell Air Movement within three (3) months from the date of order entry. If shipment is delayed for reasons beyond control of Hartzell Air Movement and is not made within three (3) months from date of order entry, prices are subject to change at Hartzell Air Movement's option.

PAYMENT TERMS

TAXES - Any tax or other governmental charge now or hereafter levied upon the reproduction, sale, use or shipment of goods ordered or sold will be charged to and paid for by Buyer. Such taxes are not included in Hartzell Air Movement's price unless expressly so provided.

TERMS OF PAYMENT - Terms of payment are Net 30 days from the date of invoice. If shipment is delayed by the Buyer or Carrier, Hartzell Air Movement may generate shipping paperwork, including the sales invoice, on or after the acknowledged ship date. The date of invoice will constitute the start date for payment terms. If, in Hartzell Air Movement's judgment, the Buyer's financial condition at any time does not justify normal payment terms, Hartzell Air Movement may require full or partial payment as a condition to commencing or continuing manufacture, or in advance of shipment, or, if shipment has been made, recover equipment from the carrier. Storage and Handling fees shall be charged for any delay shipments caused by the buyer. A late charge of 1.5% per month, a rate of 18% per annum, or the maximum permitted by law, whichever is less, will be imposed on all past due invoices unless otherwise agreed in writing.

FREIGHT - Customer can elect "Prepaid and Add" (PPD/Add) or "Collect" freight terms.

PPD/ADD - Hartzell will arrange and prepay the freight. Title and goods will be transferred Ex-Works

Piqua, Ohio. Freight charges at time of shipment will be added to invoice and follow payment terms.

Collect – Buyer is responsible for and makes the freight arrangements, including Collect/LTL destinations. Title and goods will be transferred Ex-Works Piqua, Ohio. The buyer bears all responsibility for the equipment during transit and will bear all freight costs.

GOODS MANUFACTURED BY OTHERS - Hartzell Air Movement has no responsibility whatever with respect to goods sold but not manufactured by Hartzell Air Movement and Buyer's sole recourse is against the manufacturer of said goods. Hartzell Air Movement will assign to Buyer any pertinent warranty rights received by Hartzell Air Movement from manufacturer.

PATENTS - Hartzell Air Movement shall defend any suit or proceeding brought against the Buyer insofar as based on a claim that any goods sold by Hartzell Air Movement, or any part thereof constitutes an infringement of any patent of the United States, if notified promptly in writing and given to authority, information and assistance for the defense of same, and Hartzell Air Movement shall pay all damages and costs awarded therein against the Buyer. In case said Hartzell Air Movement goods, or any part thereof, is in such suit held to constitute infringement and the use of said goods is enjoined, Hartzell Air Movement shall, at its own expense and at its option, either procure for the Buyer the right to continue using said goods; or replace same with non-infringing equipment; or modify it so they become non-infringing; or remove said goods and refund purchase price and the transportation and installation costs thereof. The foregoing states the entire liability of Hartzell Air Movement for patent infringement.

The preceding paragraph shall not apply to any goods or any part thereof not manufactured by Hartzell Air Movement or to any goods or any part thereof, manufactured to Buyer's design, nor for any use to which any such goods may be put as a part of any system, mechanism or process covered by patent rights of others. As to such goods or any part thereof, Hartzell Air Movement assumes no liability whatsoever for patent infringement. If any claim is asserted against Hartzell Air Movement that products manufactured by Hartzell Air Movement in compliance with Buyer's specifications or design infringes on any United States patent or copyright, then the buyer shall defend and indemnify Hartzell Air Movement for any damages and costs.

INTELLECTUAL PROPERTY - The design, performance information, construction detail of Hartzell Air Movement goods or any part thereof, is proprietary, and remains the valuable property of Hartzell Air Movement. Buyer agrees not to copy or duplicate the goods or any part thereof, or information related thereto provided without express written authorization from Hartzell Air Movement.

LIMITED WARRANTIES - Hartzell Air Movement warrants to Buyer that any goods to be delivered hereunder will be produced in compliance with the requirements of the Fair Labor Standards Act of 1938 as amended.

Hartzell Air Movement also warrants to Buyer its goods to be free from defects in workmanship and material under normal use and service for two (2) years after tender of delivery by Hartzell Air Movement. Subject to the following limitations and conditions, the warranty will be extended to five (5) years after tender of delivery, if Buyer registers the product on-line at www.hartzellairmovement.com/five-year-warranty within ninety (90) days after tender of delivery. If the five (5) year warranty applies, applicability of the warranty to any claim arising after two (2) years after tender of delivery is conditioned upon Buyer providing to Hartzell Air Movement maintenance records (prepared contemporaneously with the performance of the maintenance) demonstrating that the product has been maintained (from the time of tender of delivery to the time the warranty claim arises) in accordance with Hartzell Air Movement's Installation, Operation and Maintenance Manual.

Goods manufactured by a third party ("Third Party Product") may constitute, contain, be contained in, incorporated into, attached to or packaged together with, the goods manufactured by Hartzell Air Movement, including but not limited to, motors. Third Party Products are not covered by foregoing warranty. For the avoidance of doubt, SELLER MAKES NO REPRESENTATIONS OR WARRANTIES WITH RESPECT TO ANY THIRD-PARTY PRODUCT, INCLUDING ANY (a) WARRANTY OF MERCHANTABILITY; (b) WARRANTY OF FITNESS FOR A PARTICULAR PURPOSE; (c) WARRANTY OF TITLE; OR (d) WARRANTY AGAINST INFRINGEMENT OF INTELLECTUAL PROPERTY RIGHTS OF A THIRD PARTY; WHETHER EXPRESS OR IMPLIED BY LAW, COURSE OF DEALING, COURSE OF PERFORMANCE, USAGE OF TRADE, OR OTHERWISE.

The only warranty applicable to a Third Party Product is the warranty, if any, of the manufacturer of the Third Party Product. Hartzell Air Movement will provide to Buyer information regarding submission of a warranty claim to the manufacturer of a Third Party Product, but Hartzell Air Movement does not represent or assure that the warranty, if any, of the manufacturer of the Third Party Product.

Any extension of any applicable warranty period beyond that indicated above is effective only if the extension is granted by Hartzell Air Movement in writing. No warranty extends to future performance of goods, and any claim for breach of warranty or otherwise accrues upon tender of delivery.

Replacement of belts and other parts as a result of ordinary wear and tear is not covered by this warranty and is the responsibility of the Buyer.

The foregoing constitute Hartzell Air Movement's sole and exclusive warranties and are in lieu of all other warranties, whether written, oral, express, implied or statutory.

LIMITATION OF LIABILITY FOR BREACH OF WARRANTY - Hartzell Air Movement's obligation for any breach of warranty is limited to repairing or replacing, at its option, without cost to Buyer at its factory any goods which shall, within such a warranty period, be returned to it with transportation charges prepaid, and which its examination shall disclose to its satisfaction to have been defective. Any request for repair or replacement should be directed to Hartzell Air Movement, Inc., 910 S. Downing Street, Piqua, Ohio 45356. Hartzell Air Movement will not pay for any repairs made outside its factory without its prior written consent. Hartzell Air Movement has no obligation to repair or replace any Hartzell Air Movement goods which have failed as a result of faulty installation or abuse, or incorrect electrical connections or alterations made by others, or use under abnormal operating conditions or misapplication of the goods.

LIMITATION OF LIABILITY - To the extent the above limitation of liability for breach of warranty is not applicable, the liability of Hartzell Air Movement on any claim of any kind, including negligence, for any loss or damage arising out of or connected with, or resulting from the sale and purchase of the goods or services covered by these Terms and Conditions of Sale or from the performance or breach of any contract pertaining to such sale or purchase or from the design manufacture, sale, delivery, resale, installation, technical direction installation, inspection repair, operation or use of any goods or services covered by these Terms and Conditions shall, in no case exceed the price allocable to the goods or services which gave rise to the claim and shall terminate one year after tender of delivery of said goods or services, plus six months allowance for shipment to approved stocking dealers and distributors.

In no event whether as a result of breach of contract, or warranty or alleged negligence, defects, incorrect advice or other causes, shall Hartzell Air Movement be liable for special or consequential damages, including, but not limited to, loss of profits or revenue, loss of use of the equipment or any associated equipment, cost of substitute equipment, facilities or services, down time costs, or claims of customers of the Buyer for such damages. Hartzell Air Movement neither assumes nor authorizes any person to assume for it any other liability in connection with the sale of its goods or services.

NO IMPLIED WARRANTIES OF MERCHANTABILITY OR FITNESS – HARTZELL AIR MOVEMENT DOES NOT WARRANT THAT SAID GOODS ARE OF MERCHANTABILITY QUALITY OR THAT THEY ARE FIT FOR ANY PARTICULAR PURPOSE. THERE IS NO IMPLIED WARRANTY OF MERCHANTABILITY AND THERE IS NO IMPLIED WARRANTY OF FITNESS.

REGULATORY LAWS AND/OR STANDARD - Hartzell Air Movement makes no promise or representation that its product will conform to any state or local laws, ordinances, regulations, codes or standards, except as particularly specified and agreed upon in writing. Hartzell Air Movement's prices do not include the cost of any related inspection permits or inspection fees.

EXCLUSIVE FORUM SELECTION CLAUSE - Any claims relating to these Terms and Conditions of Sale of the goods or services thereunder shall be brought (if subject matter jurisdiction exists) solely in the United States District Court for the Southern District of Ohio (Western Division). In the absence of subject matter jurisdiction in that Court, any such claims shall be brought solely in any Common Pleas Court of the State of Ohio within the area encompassed by the United States District Court for the Southern District of Ohio (Western Division).

NO DELEGATION - Buyer may not perform any duties under these Terms and Conditions of Sale through a delegate.

NO ASSIGNMENT - The rights of the Buyer hereunder cannot be assigned.

NO MODIFICATION, RESCISSION OR WAIVER - These Terms and Conditions of Sale are not subject to modification, rescission or waiver except by a writing signed by an officer of Hartzell Air Movement.

NO THIRD PARTY BENEFICIARY - These Terms and Conditions of Sale are for the benefit of Hartzell Air Movement and the Buyer and not for any other person.

GENERAL - All proposals are made and all orders are accepted by Hartzell Air Movement with the reference to the laws of the State of Ohio and the rights and duties of all persons and the construction and effect all provisions thereof shall be governed by the construed according to the laws of the State of Ohio.

The invalidity of any clause or provision of these Terms and Conditions of Sale shall not affect the validity or enforceability of any other clause or provision contained herein.

01/01/2024

HARTZELL GAS FIRED DOOR HEATER
SERIES 79
MODELS DH22 AND DH24

1. DESCRIPTION

The Hartzell gas fired door heater is designed to instantly direct a high velocity of heated air towards a large door opening when the door is opened in cold weather. It utilizes a ring type burner operated on natural gas or propane. Airflow is generated via a Hartzell Ductaxial solid one-piece aluminum impeller directly coupled to an industrial duty, totally enclosed motor.

The direct-fired burner was designed and is manufactured by Hartzell and is based on many years of experience in the direct-fired gas makeup and crop dryer markets.

Products of combustion, which are discharged directly into the main airstream, consist primarily of carbon dioxide and water vapor with traces of other elements such as carbon monoxide. At maximum rated heat output, the concentration of carbon dioxide is approximately 2000 PPM compared to a maximum allowable 5000 PPM exposure limit for an 8 hour work day. The unit should be installed so that it fires after the door begins to open and shuts down as soon as the door is fully closed. If the unit is configured to be operable when the overhead door is closed, the area must have sufficient ventilation, including clean makeup air, to prevent the buildup of byproducts of combustion.

Although water vapor is added during combustion, relative humidity is actually reduced due to the heat that is added to the air. At maximum rated heat output, and assuming 60°F saturated entering air, the discharge is less than 5% relative humidity.

2. Mounting Positions

- a. Housing: The standard unit may be installed at any angle between horizontal and vertical down airflow. The control cabinet is on the left-hand side when facing the airstream. It is recommended that the unit be mounted so that the back panel of the control cabinet lay within a vertical plane.
- b. Plumbing: The gas piping enters the unit from the side of the fan. The valves should be oriented with the top of the valves laying anywhere between horizontal and vertical up. The valves should never be oriented with the top of the valves pointing down. Adjustments can be made by loosening the two unions in the plumbing and rotating the valves to the desired location.

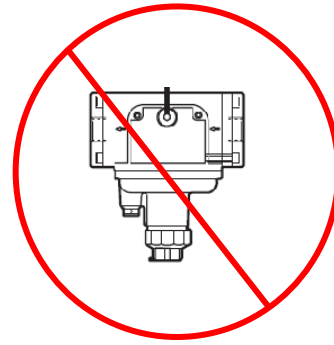
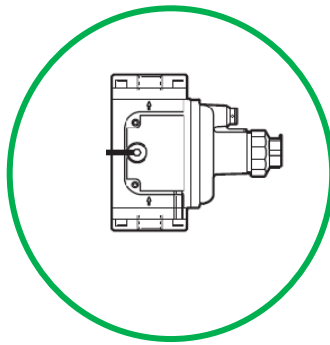
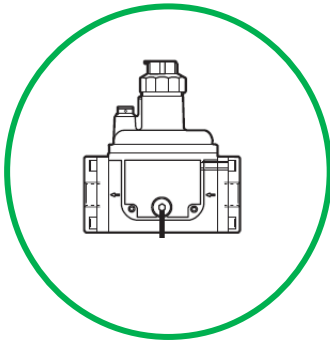

3. Installation (Mechanical)

One 24" door heater can handle up to approximately a 12' X 16' door opening. Larger openings require two or more heaters. See sizing chart below.

CAUTION: Door heater may not function as desired if building pressure is excessively negative due to the increased velocity of the incoming cold air when as the door opens. A tempered air makeup unit should be used in order to replace the air lost through exhaust ventilation.

The unit should be suspended by the mounting lugs welded to the side of the housing. The lugs are positioned to allow the unit to be installed anywhere from horizontal to vertical. Typically, units are suspended by using steel angles, threaded rod, or other structural channels. Suspending the unit with chains, cables or other flexible means is not recommended unless sufficient bracing is used to prevent movement of the unit during operation as this will put strain on the gas piping. A flexible gas hose can be used to prevent strain on the supply plumbing.

The door heater should be positioned so as to direct the airflow at a spot roughly 5 feet inside of the door opening and about halfway across the opening. There should be no obstructions within 24" of the inlet of the unit and no obstructions to the discharge of the fan. Be sure that there are no combustible materials within 3 feet of the unit. Also, make sure to leave access to the control cabinet and plumbing for maintenance.

Overhead Door

Mounted at a 45° or 30° angle, the Hartzell Automatic Door Heater directs a flow of hot air to the floor area just inside the doorway. The door switch turns on the heater when the door is opened.

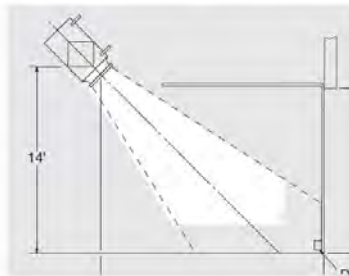

Roll Top Door

Alternate vertical mounting of the Hartzell Automatic Door Heater may also be used with roll top or straight lift doors, directing a flow of hot air to the floor just inside the door opening.

NOTE: It is recommended the door switch be mounted 24" from floor level.

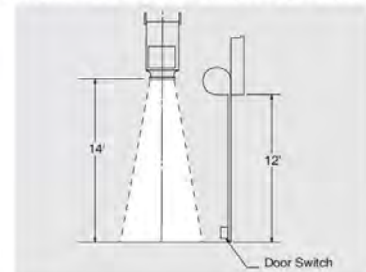

DIMENSIONS, RATING TABLE AND DOOR HEATER SIZING

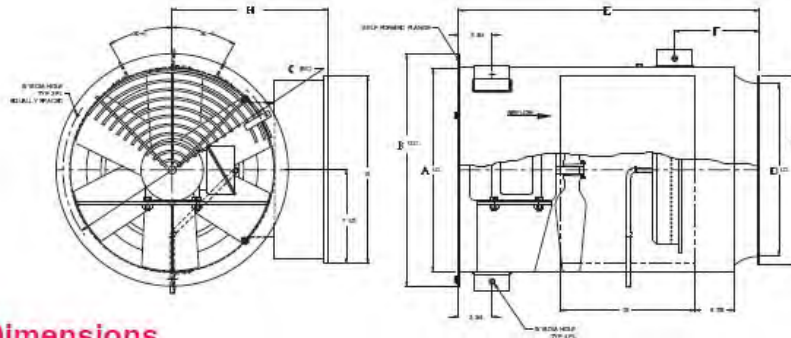

Principal Dimensions

Size	A	B	C	D	E	F	G	H
22	22 ^{7/8}	26 ^{1/16}	24 ^{1/2}	20	32 ^{11/16}	8 ^{7/16}	21 ^{1/2}	17 ^{1/2}
24	24 ^{7/8}	28 ^{1/16}	26 ^{3/8}	22	34 ^{3/16}	9 ^{9/16}	24	18 ^{1/2}

NOTE: Specifications are subject to change. Certified prints are available.

Rating Table

Model No.	Code No. Size	Motor H.P.	Fan RPM	CFM	Input BTU	Outlet Velocity	Final Temp. 70° Ent. Air	Temp. Rise	Inlet Gas Pressure
DH22	022	1 ^{1/2}	1750	6,500	700,000	3,000	169°	99°	5"
		1 ^{1/2}	1750	6,500	765,000	3,000	179°	109°	6"
		1 ^{1/2}	1750	6,500	820,000	3,000	187°	117°	7"
DH24	024	2	1750	7,900	865,000	3,000	171°	101°	6"
		2	1750	7,900	930,000	3,000	179°	109°	7"
		2	1750	7,900	990,000	3,000	186°	116°	8"

NOTE: Based on Natural Gas Specific Gravity 0.6
1000 BTU per cu.ft.
Shipping weights: DH22, 350 lbs.; DH 24, 400 lbs.

Automatic Door Heater Sizing Information

Door Size	Unit	No. of Units	Input BTU per Unit
12 x 12	DH22	1	750,000
12 x 14	DH22	1	820,000
12 x 16	DH24	1	930,000
14 x 16	DH22	2	700,000
16 x 18	DH24	2	865,000
16 x 20	DH24	2	930,000

For door sizes not covered, determine size and number of units on basis of approximately 5500 BTU/sq. ft. of door opening.

NOTE: For proper application of Hartzell Automatic Door Heaters, the maximum square foot opening should not exceed 360 sq. ft.

4. GAS PRESSURE REGULATOR

A built-in gas pressure regulator with gas filter is provided as standard with the door heater that is capable of inlet gas pressures of up to 7 psi with 1 to 5 psi being recommended. Required gas pressure to the burner will be between 5-7 in w.c. for 22" units and 6-8 in w.c. for 24" units. The rating table above lists the operating gas pressure required to achieve the desired BTU's using natural gas. If using propane, reduce pressures by half. Note these pressures need to be set with the unit in operation. Gas pressure to the burner can be read from the provided gage on the

downstream side of the valve assembly by holding in the push-to-test valve. Note that this regulator has a vent line connection with factory installed vent limiting means to reduce gas flow to no more than 0.5 CFH @ 5psi in the event of a leak. The regulator should be vented to outside unless local code permits the use of vent limiting means in lieu of venting. For further information, please see regulator instructions. It is recommended that a gas shutoff be installed upstream of the unit for maintenance purposes. Make sure that the vent line is the correct size with no kinks or other obstructions. Poor venting can lead to poor regulator operation.

5. ELECTRICAL INSTALLATION

Confirm that supply voltage matches the controls ordered for the unit (230v, 460v or 575v 3 phase). All control circuits are 115V and are supplied by the control cabinet. All internal wiring is factory installed. The only required connections to be made are for incoming power to the disconnect switch (if provided) or to the top of the motor starter and wiring to the door switch and remote station.

The remote station may be installed at any convenient location but is typically installed next to the door. The remote station contains a three position selector switch:

“SUM” – “summer mode”, allows continuous fan operation without heat

“WIN” – “winter mode”, enables operation of fan and burner when door opens

“OFF”

All electrical wiring between the main control cabinet and remote station are made to the terminal blocks in the main cabinet. Simply match the terminal numbers in the cabinet to those labeled on the remote station. See wiring diagram E029 for further information. Wiring between the door heater and remote station should be minimum 14 gage with a 60 degree C rating, of the the appropriate wire color and be labeled with the wire number.

Install the door switch to the door frame in such a way so that it trips as the door starts to open and just before it fully closes to prevent as much cold air as possible from infiltrating the facility. Typically, the switch is installed so that it is “tripped” when the door is fully closed and the normally closed contacts are used.

6. Installation (Gas Piping)

CAUTION: When making up gas piping, be sure all valves are in a horizontal portion of the gas line with valve body properly positioned. It is recommended that incoming gas

pipng be 1" or larger to ensure sufficient gas flow to the unit. Major components of the gas train are called out below for reference.

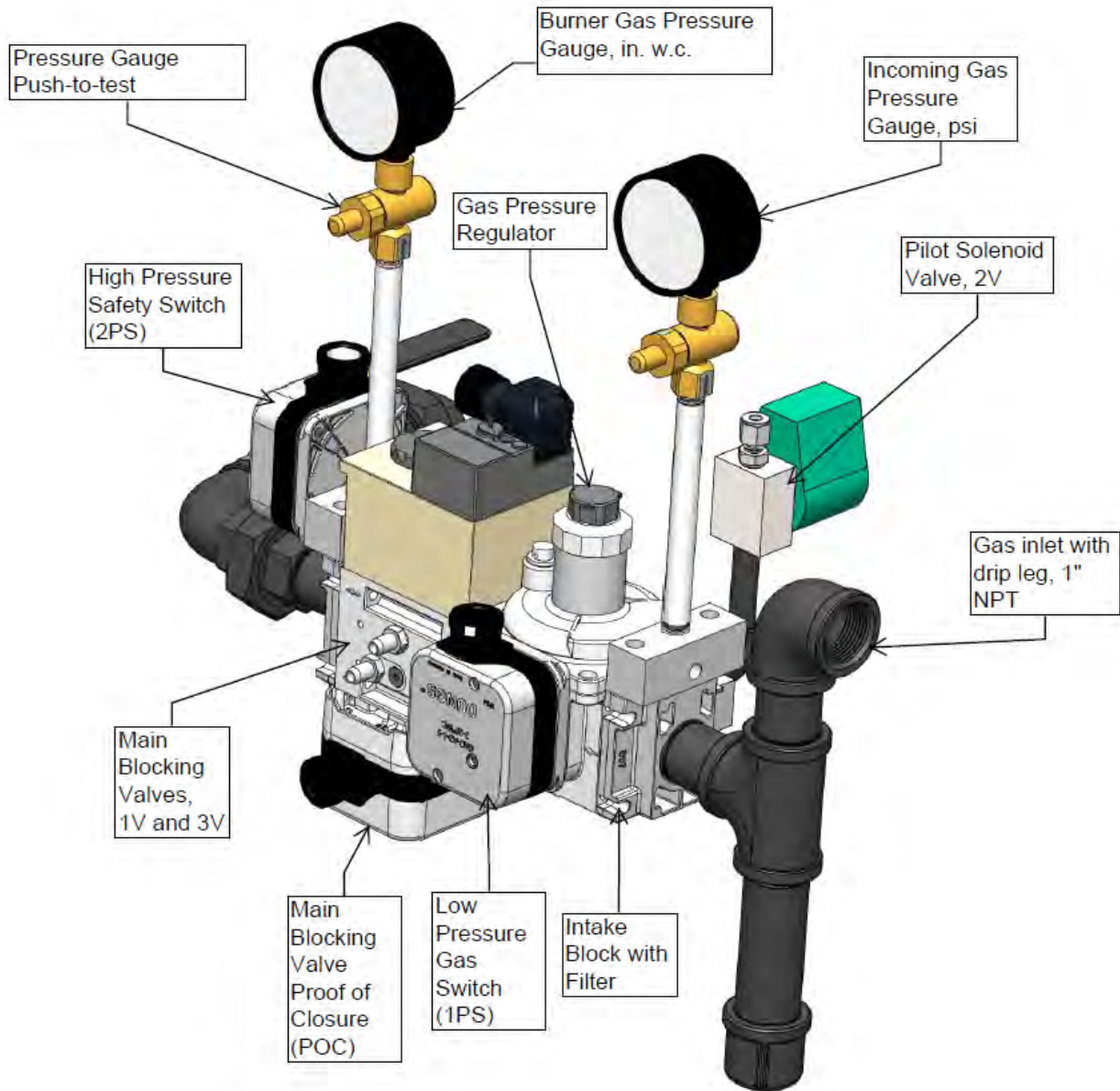

7. SAFETY DEVICES AND OTHER CONTROLS

- (A) Low and High Gas Pressure Switches (1PS and 2PS): These will shut down the unit and/or prevent it from starting when the supply gas pressure is too high or too low. When tripped, 1CR will energize and the green “flame out/turn reset” light on the remote station will illuminate. To reset, the selector switch on the remote station must be turned to “off” and back to “run”. Switches settings are pre-set at the factory. The low pressure switch should be set to 4” w.c. and the high pressure should be set to 10” w.c.
- (B) Safety Shutoff Valve Proof of Closure Switch: Valves are quick open, instant close type. The attached valve proof of closure switch ensures that valve is fully closed before allowing the unit to try for ignition.
- (C) High Temperature Limit Switch: A bi-metallic, mechanical high temperature limit switch is located near the discharge of the unit inside of a small enclosure. The switch will trip if discharge temperature exceeds 225 degrees F and is not adjustable. The switch is normally closed and opens when tripped and must be manually reset. If the unit trips on high temperature, check the unit for too high of gas pressure to the burner, insufficient airflow through the unit or other conditions which would cause excessive discharge temperature.
- (D) Airflow Proving Switch: A mechanical differential pressure switch that detects airflow by sensing negative pressure upstream of the impeller. This switch closes when sufficient airflow is detected.
- (E) Flame Safeguard (CRE): Honeywell RM7890A1056. The unit controls the ignition sequence and monitors the pilot and main burner flame. The unit will prevent ignition if it senses flame when there should not be a flame. After the burner is lit, it monitors the flame and will disable the unit in the event of a flame failure. If either occurs, check the unit for proper gas pressure or other abnormalities. The unit will need to be reset inside of the control cabinet. Also, the CRE will not try-for-ignition until all safety switches are satisfied.
- (F) Fan motor starter: Although not a traditional safety device, the unit is wired so that the gas system cannot be energized prior to the fan starting.
- (G) Optional outdoor thermostat (1THS): Optional outdoor thermostat prevents the burner from igniting when the outdoor temperature exceeds the set point. Note, if

used, make sure to remove the jumper wire from terminals 3 and 4 inside the control cabinet.

(H) Both sides of the primary and secondary transformers are fused.

(I) Motor starter overloads. These are pre-set at the factory and will disable the fan and heating system in the event of excessive motor amp draw.

8. STARTUP

- a. Make sure door switch, remote station and outdoor thermostat (if used) are properly mounted and wired. Set selector switch on remote panel to "off"
- b. Check supply power for proper voltage (230, 460 or 575 VAC, 3P)
- c. Turn on gas and check all plumbing connections for leaks.
- d. Confirm incoming gas pressure to the unit. 1 to 5 psi is recommended. Do not exceed 7psi.
- e. Open door.
- f. Turn selector switch "sum" and back to "off" to "bump" the motor. Check prop rotation, it should be clockwise when looking into the unit and air should flow out of the discharge. If rotation is incorrect, switch two of the phase wires and try again.
- g. Turn remote selector switch to "win" position and open door (if not already open). The fan should immediately start when door switch trips. Within 10-15 seconds, the pilot should ignite. The pilot flame should be roughly the size of a golf ball. The rest of the burner should light very quickly after establishment of the pilot flame. The pilot should extinguish after 5 seconds. Note: the unit may not light on the first try due to air inside of the gas line. If unit does not ignite, turn selector switch to "off" and then back to "win" and let the unit try again. This may need to be repeated several times until all air is purged from the gas line.
- h. With unit running, adjust gas pressure regulator to desired pressure (between 5 and 8 in w.g.) using the sizing chart on page 4 as a guide.
- i. Allow unit to run for several minutes to allow any trapped air to purge and to ensure unit runs correctly.
- j. Close door and check for proper shutdown. Burner should immediately extinguish and fan will coast to a stop.

If you are experiencing problems starting the unit, consult the trouble shooting section below. If problems persist, contact Hartzell direct at (800)-336-3267 or (937) 773-8494 and ask for technical support.

9. MAINTENANCE

(Note: See wiring diagram for part number and manufacturer of any control component. See manufacturer's instruction sheets for more information.)

- (A) Fan motor: Motor bearings are lubricated for the life of the motor and do not require any additional lubrication. If issues with motor arise, have the motor serviced at a local EISA motor shop or replace motor with one of the same voltage, speed, HP and NEMA frame size. Note, motor starter overloads may need to be adjusted based on the FLA rating of the new motor.
- (B) Burner: Sides should be checked for excessive buildup of fouling annually and cleaned as needed with a wire brush.
- (C) Burner: Gas ports should be drilled every heating season or as needed with either a #47 or a 5/64" drill bit (extension may be required) to remove any carbon buildup and maintain burner performance.
- (D) Flame scanner: Clean annually by removing flame scanner from side of unit and wiping lens with a soft cloth. Also, make sure that pipe nipple is clear of any dirt or other debris.
- (E) Spark Ignitor: Ignition takes place by means of a spark arching from the ignitor to the burner. The spark gap should be 1/8" to 1/4" and located downstream of an air mixing hole so that there is a gas-air mixture to ignite. Check for carbon bridging between the electrode and burner and clean if necessary. Also, remove the protective boot from the top of the ignitor and clean the connection between the ignitor and ignition cable.
- (F) Shutoff valves – Check gas shutoff valves annually for leaks.

10. TROUBLESHOOTING

(A) Fan Does not Start:

- (1) Selector switch in remote station set to "OFF"
- (2) Check incoming power to unit for proper voltage across all three phases

- (3) Check for tripped motor overload in control cabinet and reset if necessary.
- (4) Check for 115V across secondary side of transformer 1T. If not, check fuses.
- (5) Turn selector switch to "SUM". If fan operates in "SUM" mode but not "WIN", check the outdoor thermostat (1 THS) (if used). If not used, ensure that there is a jumper wire from terminals 3 to 4 inside of control cabinet. Also, check for proper door limit switch operation. When the door starts to open, the contacts should close and there should be continuity from terminals 4 and 5.

(B) Fan operates, pilot does not ignite, Green "TURN RESET" does not light:

- (1) Make sure selector is in "WIN" mode
- (2) Check terminal 6 to neutral for 115V. If no voltage, check selector switch for proper function and wiring to the switch.
- (3) Check terminal 7 to neutral for 115V. If no voltage, check auxiliary contact on motor starter and wiring to starter.
- (4) Check terminal 9 to neutral for 115V. If no voltage, check contacts on low gas switch and wiring to switch.
- (5) Check terminal 10 to neutral for 115V. If no voltage, check contacts on high gas switch and wiring to switch.
- (6) Check terminal 11 to neutral for 115V. If no voltage, check NC contacts on control relay 1 CR. 1 CR should not be energized and the contacts should be closed.
- (7) Check terminal 12 to neutral for 115V. If no voltage:
 - a. Check contacts on airflow switch. With fan running, contacts should be closed.
 - b. Check air pressure sensing tube for any clogs or restrictions. Also make sure that there is ample clearance on the intake side of the unit.
 - c. Adjust pressure setting by turning adjustment screw CCW until switch is tripped. Ensure that contacts still open when fan is shut off.
- (8) Check terminal 13 to ground for 115V. If no voltage, check high temperature switch (2 THS, Therm-O-Disc) and reset. The switch is located inside of the conduit box on top of the unit.
- (9) Check toggle switch in the mounting base for the flame safeguard module (CRE). It should be left in the "ON" position. (This only applies to older units)

(C) Fan operates, Pilot will not ignite, green “TURN RESET” lights continuously whenever fan runs:

- (1) Check time delay relay TDR. It should be set to 5 seconds.
- (2) Check gas pressure for proper levels and adjust if necessary.
- (3) Turn selector switch to “OFF” and back to “WIN”.

(D) Fan operates, Pilot will not ignite, red “LOCKOUT” lights continuously whenever fan runs:

- (1) Press “reset” on CRE
- (2) If CRE will not reset, check for presence of continuous pilot flame.

Caution – If pilot flame exists, close the manual shutoff valve in the pilot line and wait for flame to extinguish before investigating the stuck-open valve.

- (3) If CRE can be successfully reset but on next try for ignition green “TURN RESET” lights, see section E or F below. If red “LOCKOUT” lights, refer to section G below.

(E) Fan operates, Little or No Pilot Flame, red “TURN RESET” lights after 5 seconds:

- (1) Check manual pilot cock, it should be fully open.
- (2) Check gas lines for clogging or air in the lines.
- (3) Check for dirt, moisture or carbon on spark ignitor.
- (4) Check for kinks or leaks in pilot line.
- (5) Take a volt reading across the test jacks on the CRE. The volt reading should be between 4 and 10 VDC when a flame is present. See manual for Fireye MEC120 for additional information.
- (6) Check gas filter on inlet side of valve block.

(F) Fan operates, pilot ignites normally then goes out, red “LOCKOUT” lights:

- (1) Check all manual shutoffs, they should all be fully open.

- (2) Check flame scanner. Remove and clean lens. Clean sight pipe to ensure no blockages.
- (3) With selector in "WIN" mode but door not operating (door closed or temporarily disconnect door switch wires), hold a match or lighter in front of the scanner. The "flame" light on the CRE should illuminate. An audible "click" may be audible if in a fairly quiet area. "Flame" indicator light on CRE should also illuminate.

Caution: before proceeding to steps 4 and 5 below, turn selector to "OFF" this will de-energize the CRE. Power may also be locked out to the unit. Failure to do this may result in electrical shock.

- (4) Disconnect flame scanner (leads #20 and #21) and install a known good scanner and repeat step 3 above. If "Flame" indicator on CRE lights, replace scanner. If not, re-install old scanner and proceed to step 5.
- (5) Replace burner amplifier card with one known to be good and repeat step 3 above. If "Flame" indicator on CRE lights, replace amplifier card. If not, go to step 6
- (6) Replace the burner controller chassis with one known to work and repeat step 3. If "Flame" indicator on CRE lights, replace chassis. If not, contact Hartzell for additional assistance.
- (7) Check 2CR for a stuck open contact.

(G) Fan operates, pilot ignites normally and then goes out as red "LOCKOUT" lights:

- (1) With fan operating in "win" mode, check for voltage across terminals 8 and 2. If no voltage, install a temporary jumper from terminals 7 to 8. If still no voltage, check for 115V across terminals 7-2, 6-2 and 5-2 to determine where the break in the circuit exists and correct problem as necessary. If 115 is present at terminal 8 check to see if 1CR pulls in. If not, replace relay. If 1CR pulls in when power is applied to terminal 8, then this part of the circuit is functioning correctly.

For additional troubleshooting of LOCKOUT condition, see next page for Fireye Lockout codes and method of determining strength of flame signal.

Fireye Programmer Lockout Codes

LOCKOUT CODES

MSGN		DESCRIPTION	OP CTRL	AIRFLOW INTLCK	PTFI	FLAME	ALARM
DEC	HEX						
6	6	Lockout Line Frequency Noise Detected	●	○	○	●	*
7	7	Lockout Flame Fail - PTFI	○	●	●	●	*
15	0F	Lockout Fault Unknown	●	●	●	●	*
16	10	Lockout Amplifier High Count Fail	○	○	○	○	*
19	13	Lockout Flame Fail - MTFI	○	○	●	●	*
20	14	Lockout False Flame - STANDBY	○	●	○	○	*
21	15	Lockout Intrlck Open	●	●	●	○	*
22	16	Lockout Intrlck Closed	○	●	●	○	*
24	18	Lockout Chassis Opto	●	●	○	●	*
37	25	Lockout Flame Fail - AUTO	○	●	○	●	*
39	27	Lockout Fuel Valve State Change	○	○	○	●	*
54	36	Lockout Check Chassis	○	○	○	●	*
55	37	Lockout Check Programmer	○	○	●	○	*
56	38	Lockout Check Amplifier	●	○	○	○	*
58	3A	Lockout Amplifier Auto Check Fail	●	○	●	○	*
59	3B	Lockout Check BLOWN FUSE	●	○	●	●	*
76	4C	Lockout Check Scanner	●	●	○	○	*

- = NOT LIGHTED
 ● = LIGHTED
 * = FLASHING

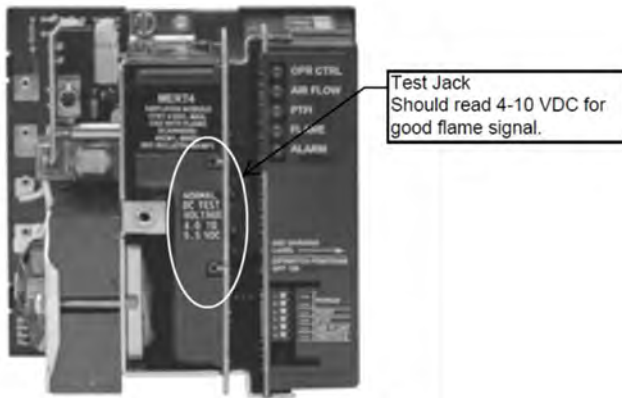

Flame signal strength can be checked by removing the red cover from the Fireye Chassis and reading the DC voltage across the test jacks located on the amplifier card. A reading of 4 to 10 VDC indicates a good flame signal. Holes may also be drilled in front cover to allow for measurements. See Fireye instruction manual MC-5000 for additional information.

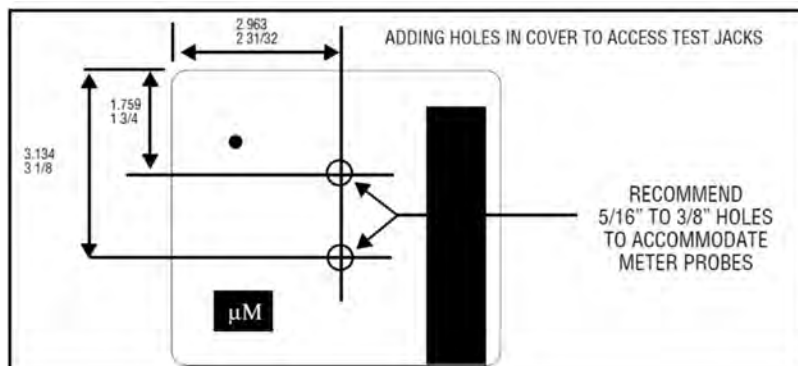

Major Component Identification – Control Cabinet

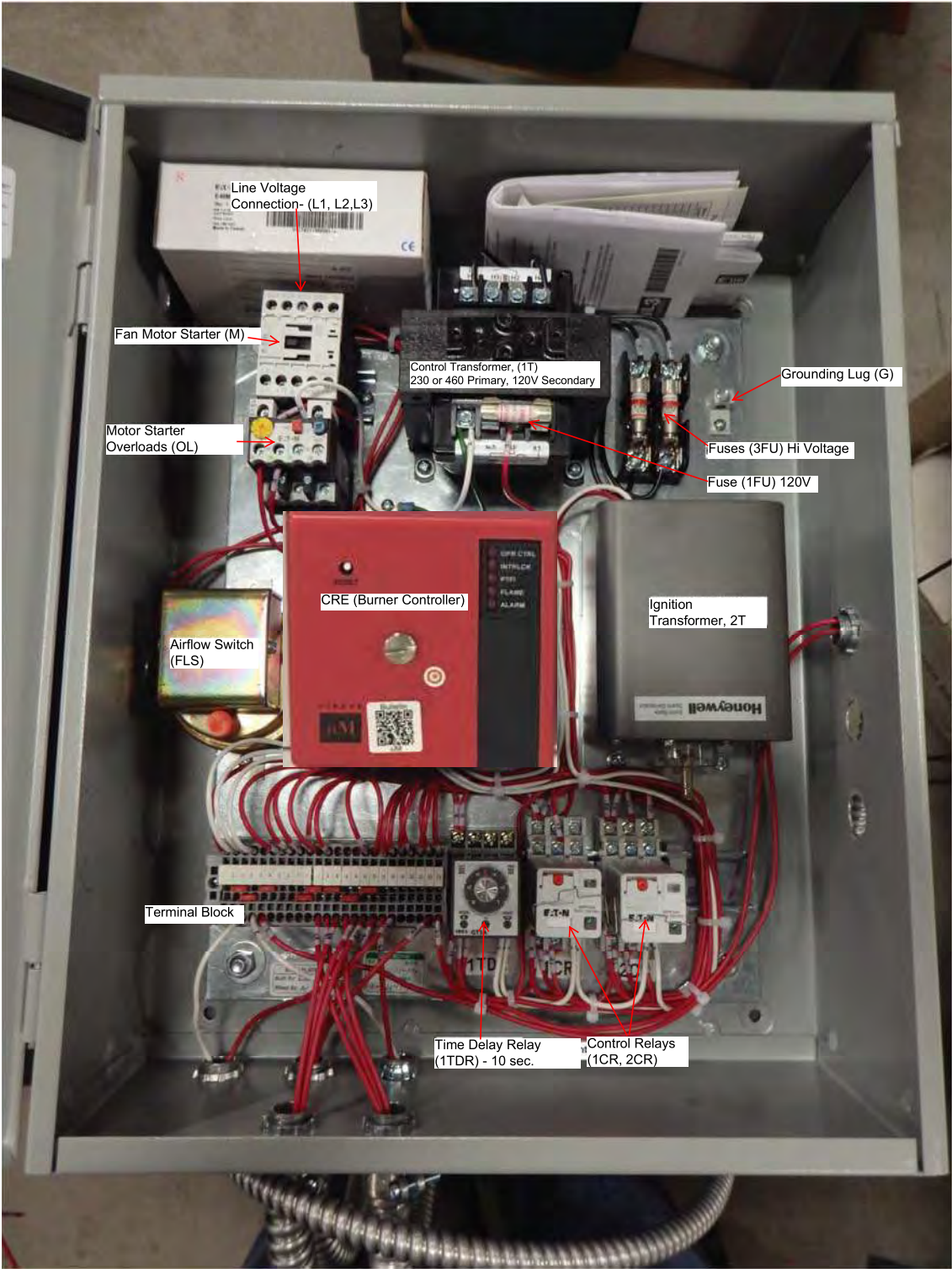

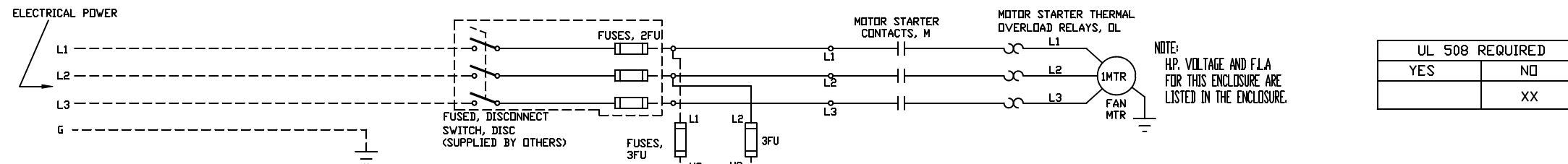

NOTE:
HP, VOLTAGE AND FLA
FOR THIS ENCLOSURE ARE
LISTED IN THE ENCLOSURE.

UL 508 REQUIRED	
YES	NO
	XX

SEQUENCE OF OPERATION

FOR SUMMER OPERATION (continuous air movement without heat), turn selector switch SS to "SUM". Fan will remain on regardless of opening and closing of factory door.

FOR WINTER OPERATION (WITH HEAT), turn SS to "WIN". Opening of factory door trips limit switch LS, starting fan and energizing gas control system, first thru auxiliary contact on fan starter M, and then thru FLS airflow switch when tripped by air movement.

NON-RECYCLING SHUTDOWN of burner on safety occurs:

- If 2THS is tripped by excessive outlet temperature;
- If flame is not sensed by CRE within 5 seconds;
- If gas pressure drops below setting of 1PS; (IRI ONLY)
- If gas pressure rises above setting of 2PS; or (IRI ONLY)
- If flame is lost after ignition and pilot is not re-established within 5 seconds.
- If (a) occurs, depress reset button on 2THS. If (b) thru (e) occurs, green "FLAMEOUT" pilot lights; to reset for another try-for-ignition, turn SS to "OFF/RESET" and then back to "WIN".

GAS PILOT IGNITES from spark ignition; CRE senses flame, interrupts spark, and energizes valve(s); safety shut-off valve(s) open(s) as vent valve closes (if used). Main burner ignites.

HEATER CONTINUES IN OPERATION until:
g) Factory door closes, tripping LS, or
h) SS is turned to "OFF".

IF RED "LOCKOUT" PILOT LIGHTS, CRE flame safeguard must be reset in the control cabinet.

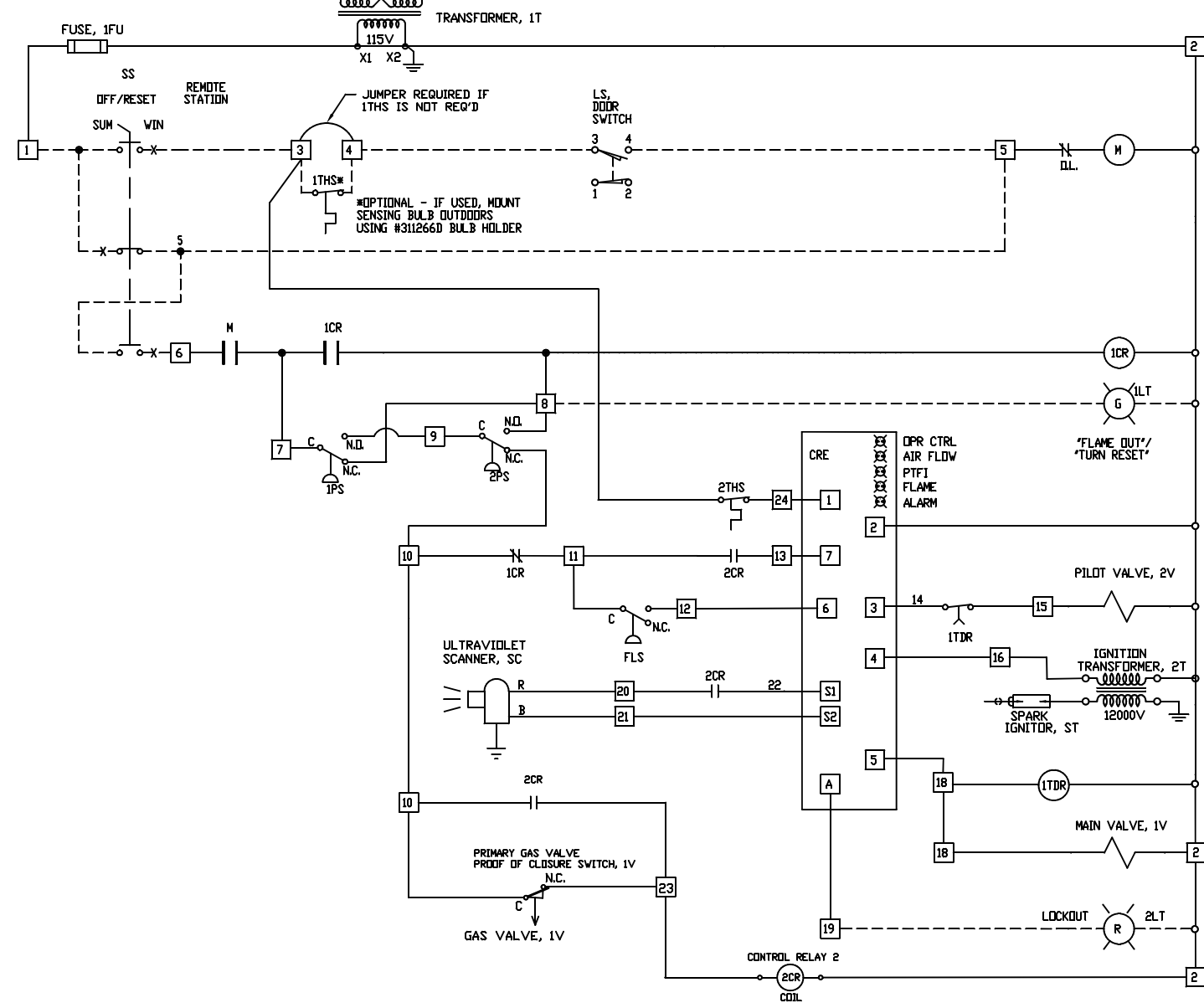

TABLE# 1 SELECTOR SWITCH SS OPERATION

CONTACTS	POSITION		
	SUM	OFF/RESET	WIN
1-3			X
1-5	X		
5-6			X

X - CONTACT CLOSURE

LEGEND

- MECHANICAL CONNECTIONS
- - - DASHED LINES ARE FIELD WIRED (BY OTHERS)
- TERMINAL STRIPS ON MAIN CONTROL PANEL

USE COPPER WIRE ONLY. WHEN:
LESS THAN 100 AMP, USE WIRE WITH 60C TEMPERATURE RATING, MIN
MORE THAN 100 AMP, USE WIRE WITH 75C TEMPERATURE RATING, MIN



NAME ELECTRICAL SCHEMATIC	DRN. J.W.	CKD.	MTL. NOTED	SCALE NONE	DRAWING NO. E029	REV. LET.
USED ON DOOR HEATERS	TR.	APPR.	PATT.	DATE 6/21/95	SHT 1 OF 2	21